

INDUSTRIAL AIR FILTRATION

ESP RANGE

600 | 1000 | 2000 | 4000 | CENTRALISED

purified[®]air

 AES ENVIRONMENTAL

INDUSTRIAL AIR FILTRATION EXPERTS

Purified Air Ltd. has been manufacturing and servicing market-leading technology to filter polluted indoor air since 1984.

CONTENTS

02

OUR SOLUTIONS

ESP 600/1000

02

Product Information
Technical Specifications

ESP 2000/4000

08

Product Information
Technical Specifications

ESP Centralised

14

Product Information
Technical Specifications

18

ABOUT US

19

CONTACT US

ESP 600/1000

VERTICALLY MOUNTED

Our Oil Mist Units features a double-pass ESP technology and is efficient at 99%. Due to their compact size and built in fan system, they can be directly mounted to a machine tool.

The ionisation voltage has been designed to run at a positive potential, reducing ozone production and making it ideal for indoor applications.

A highly efficient oil, mist and smoke collector is effective on all metalworking fluids.



KEY FEATURES

- ▶ Filters particles down to sub-micron levels
- ▶ Tested to 99% efficiency
- ▶ Low operating costs
- ▶ Minimal maintenance required
- ▶ Specifically designed for industrial application
- ▶ Energy efficient
- ▶ Removes oil, mist and smoke
- ▶ Compact design

HOW IT'S INSTALLED

Installations will be directed by the customer and can be either:

- 01** Direct mounted with plenum
- 02** Side Mounted with gallows bracket
- 03** Stand mounted separate

Note: Purified Air do not recommend Direct mounting

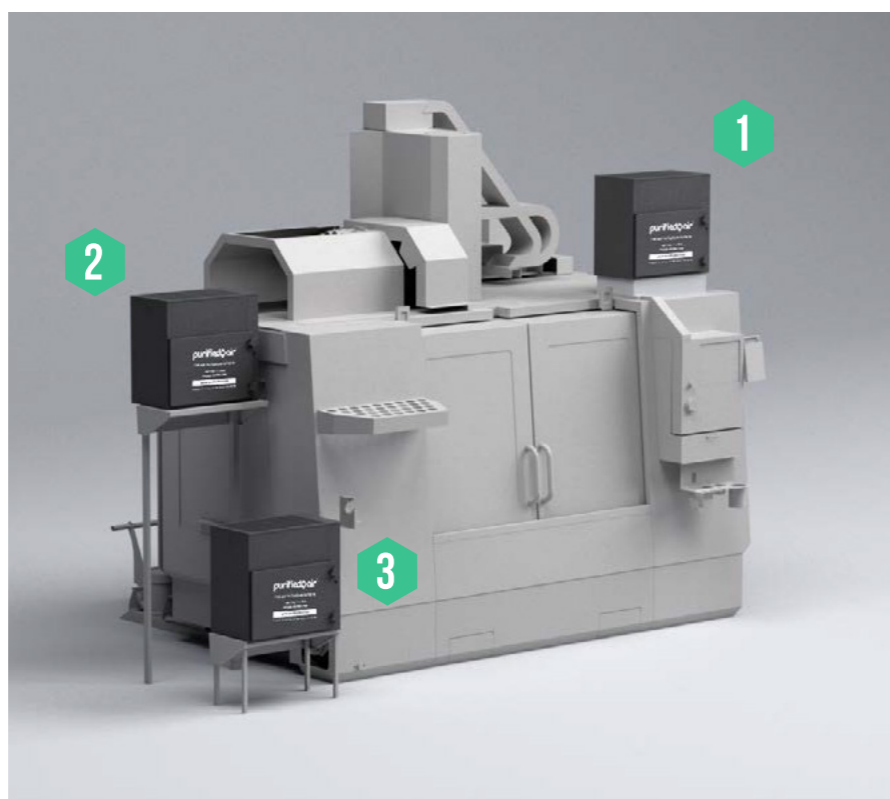

THE ELECTROSTATIC PROCESS

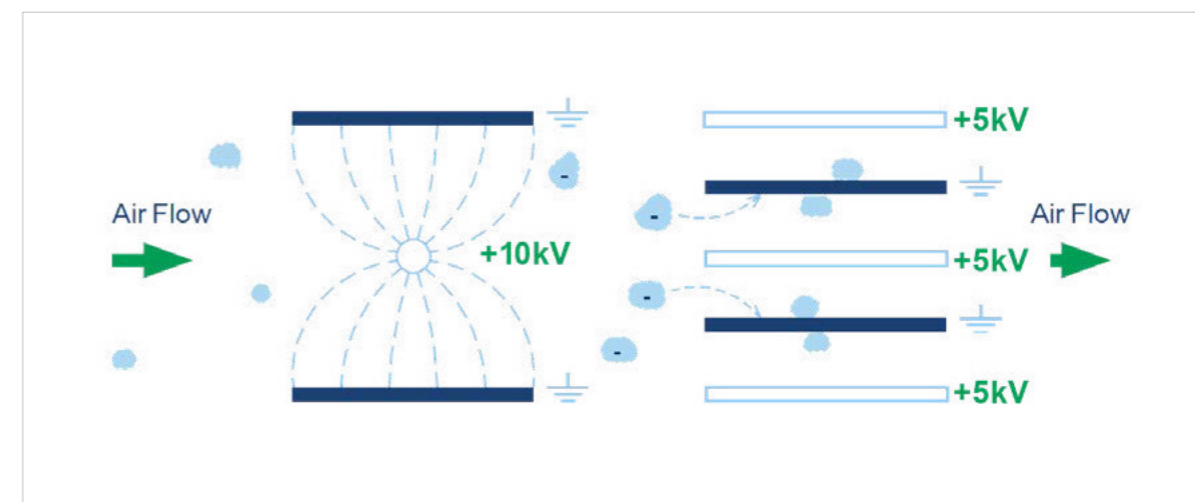

The above diagram shows, in a basic visual, how an electrostatic precipitator works:

As air passes into the combined ioniser / collector cell, the particulates in the air stream are polarised. As they continue through the ioniser and between the collector cell plates,

the polarised particulates are repelled away from the positively charged plates and attracted to the earthed plates where they stick and so are filtered out of the air flow.

FILTERS REMOVE



Smoke



Oil



Mist

THE BENEFITS OF ELECTROSTATIC TECHNOLOGY



Eliminates 99% of particles



Filters particles down to sub-micron levels



Compact design



Energy efficient

OUR SERVICES



Design



Manufacture



Maintain

TECHNICAL SPECIFICATION

	ESP 600	ESP 1000
Electrical Supply	220/240V 50Hz	220/240V 50Hz
Max Air Volume	up to 600m³/h	up to 1000m³/h
Max Power Consumption	180w	280w
Dimensions (mm)	W 625 mm	W 625 mm
	H 420 mm	H 600 mm
	D 389 mm	D 389 mm
Weight (kg)	30kg	41kg

DRAWINGS

ESP VERTICAL 600

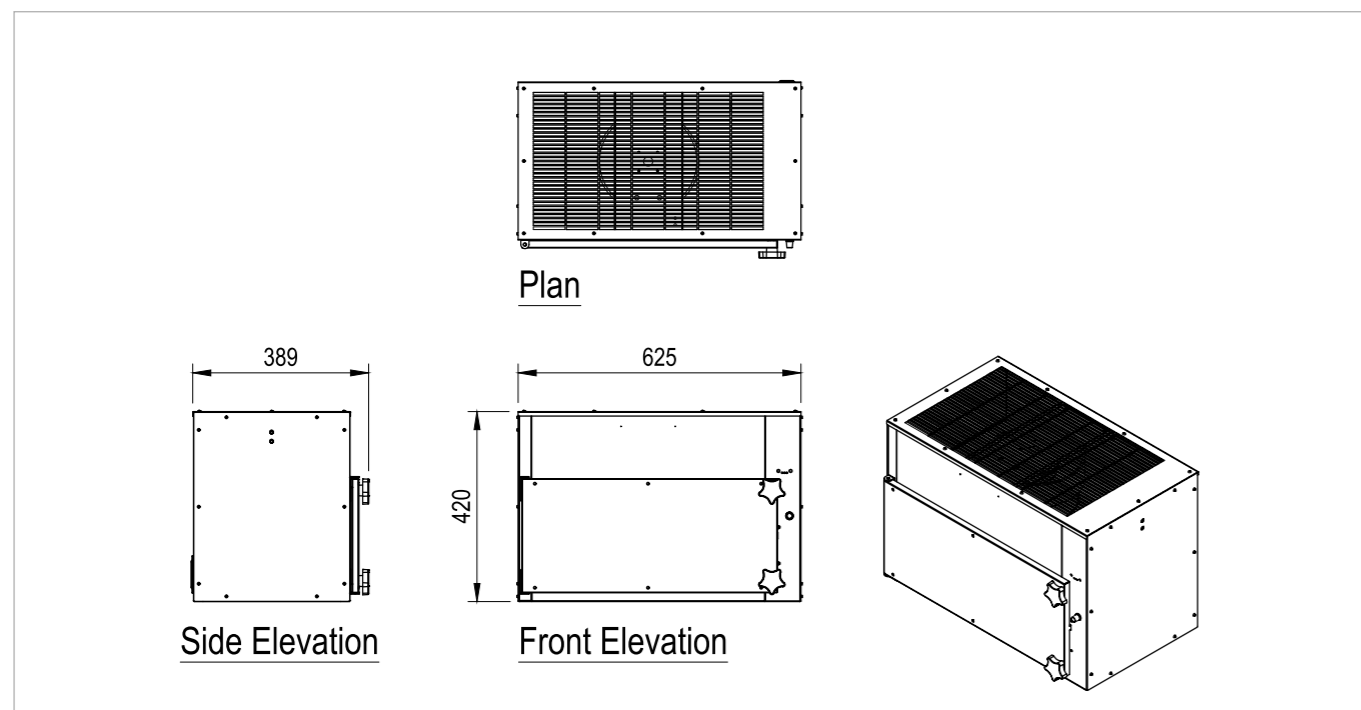

ESP VERTICAL 1000

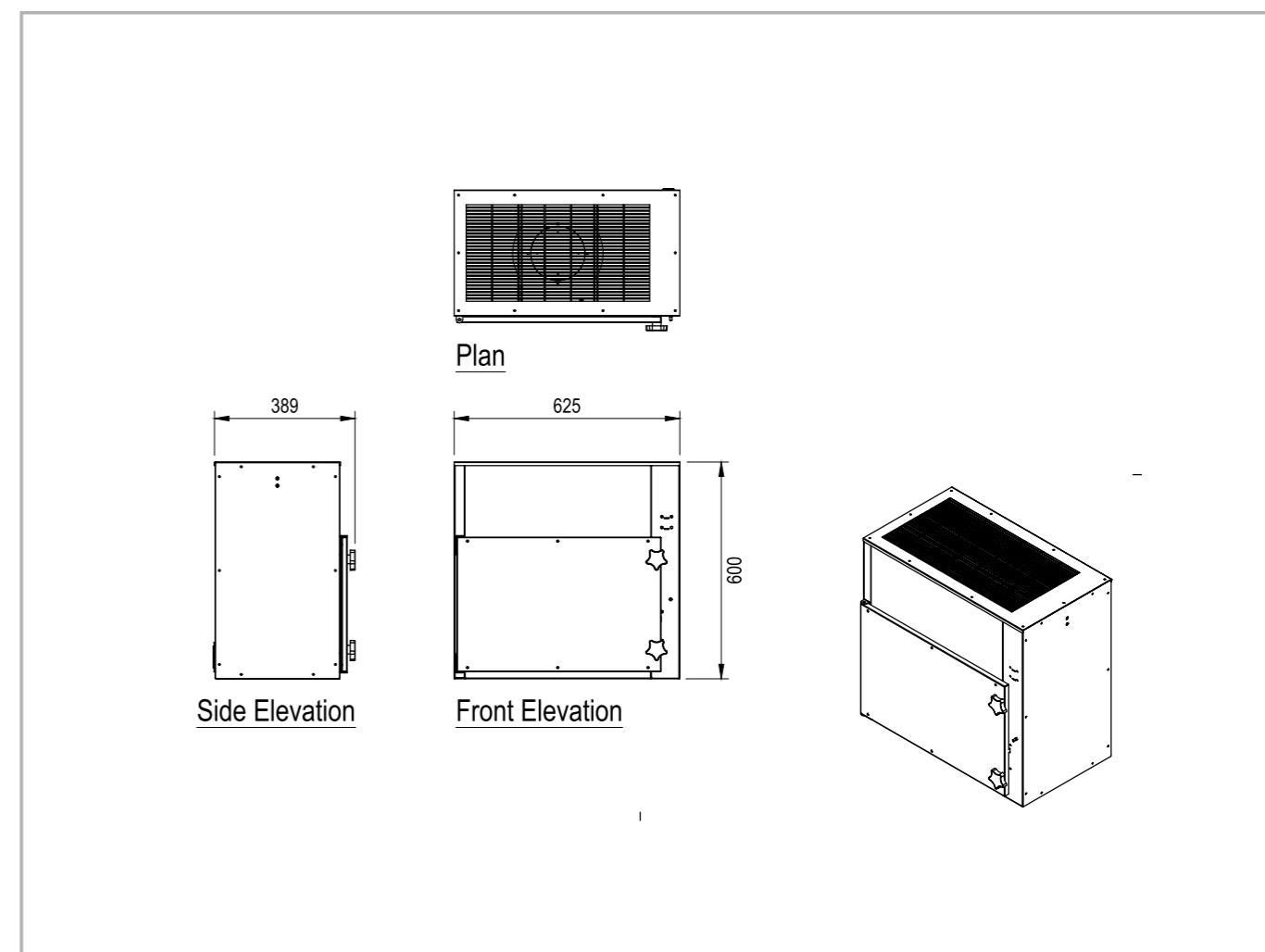

ESP 2000/4000

HORIZONTALLY MOUNTED

Our Electrostatic Precipitators, or ESPs, are up to 99% efficient. Due to their modular design and built-in fan system, the units can be mounted on a machine tool, on a freestanding stand or via a transition to allow for venting to the atmosphere.

The ionisation voltage has been designed to run at a positive potential, making it ideal for Industrial applications. This highly efficient oil mist, smoke and fume collector is effective in most manufacturing processes.



KEY FEATURES

- ▶ Filters particles down to sub-micron levels
- ▶ Tested to 99% efficiency
- ▶ Low operating costs
- ▶ Minimal maintenance required
- ▶ Specifically designed for industrial application
- ▶ Energy efficient
- ▶ Removes oil, mist and smoke
- ▶ Compact design

HOW IT'S INSTALLED

Installations will be directed by the customer and can be either:

01 Side Mounted
with gallows bracket

02 Stand mounted
separate

2000/4000 unit can be directly mounted on large machinery with plenum.

Note: Purified Air do not recommend Direct mounting.

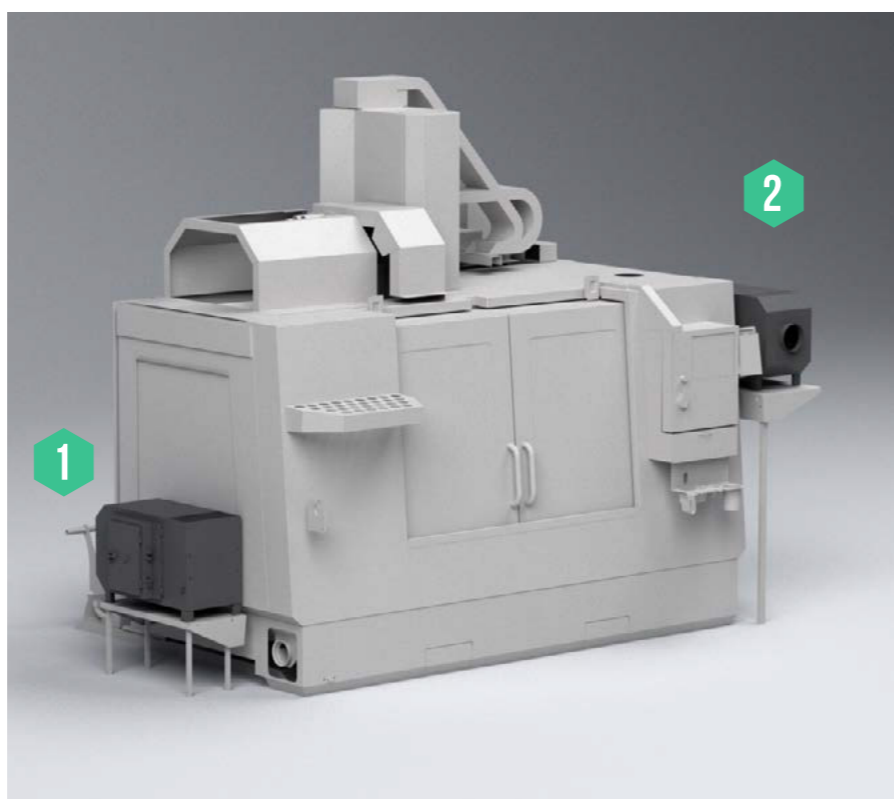

THE ELECTROSTATIC PROCESS

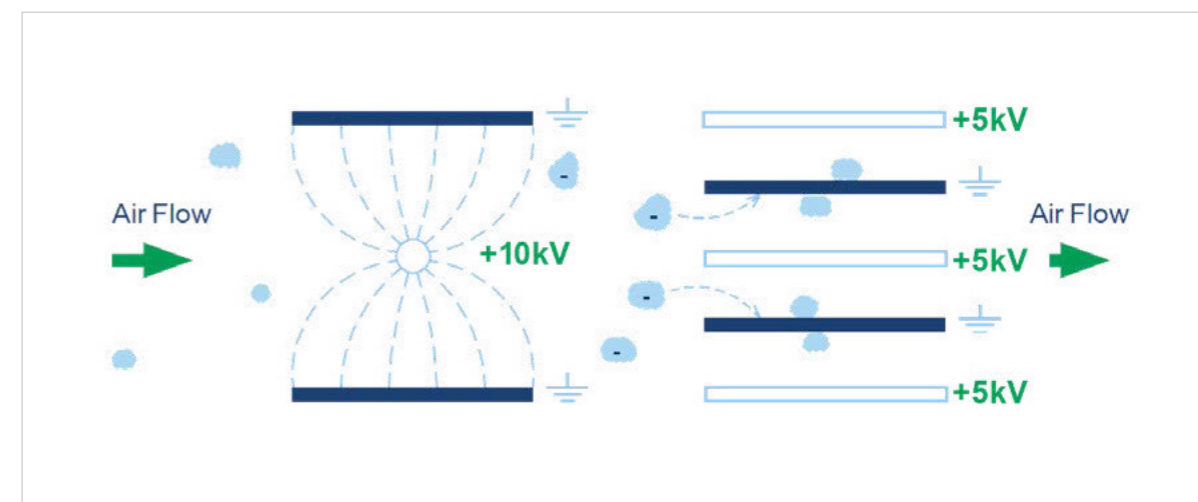

The above diagram shows, in a basic visual, how an electrostatic precipitator works:

As air passes into the combined ioniser / collector cell, the particulates in the air stream are polarised. As they continue through the ioniser and between the collector cell plates,

the polarised particulates are repelled away from the positively charged plates and attracted to the earthed plates where they stick and so are filtered out of the air flow.

FILTERS REMOVE



Smoke



Oil



Mist

THE BENEFITS OF ELECTROSTATIC TECHNOLOGY



Eliminates 99% of particles



Filters particles down to sub-micron levels



Compact design



Energy efficient

OUR SERVICES



Design



Manufacture



Maintain

TECHNICAL SPECIFICATION

	ESP 2000	ESP 4000
Electrical Supply	220/240V 50Hz	220/240V 50Hz
Max Air Volume	up to 2000m ³ /h	up to 4000m ³ /h
Max Power Consumption	390w	780w
Dimensions (mm)	W 609 mm	W 1057 mm
	H 690 mm	H 690 mm
	D 1073 mm	D 1073 mm
Weight (kg)	66kg	132kg

DRAWINGS

ESP HORIZONTAL 2000

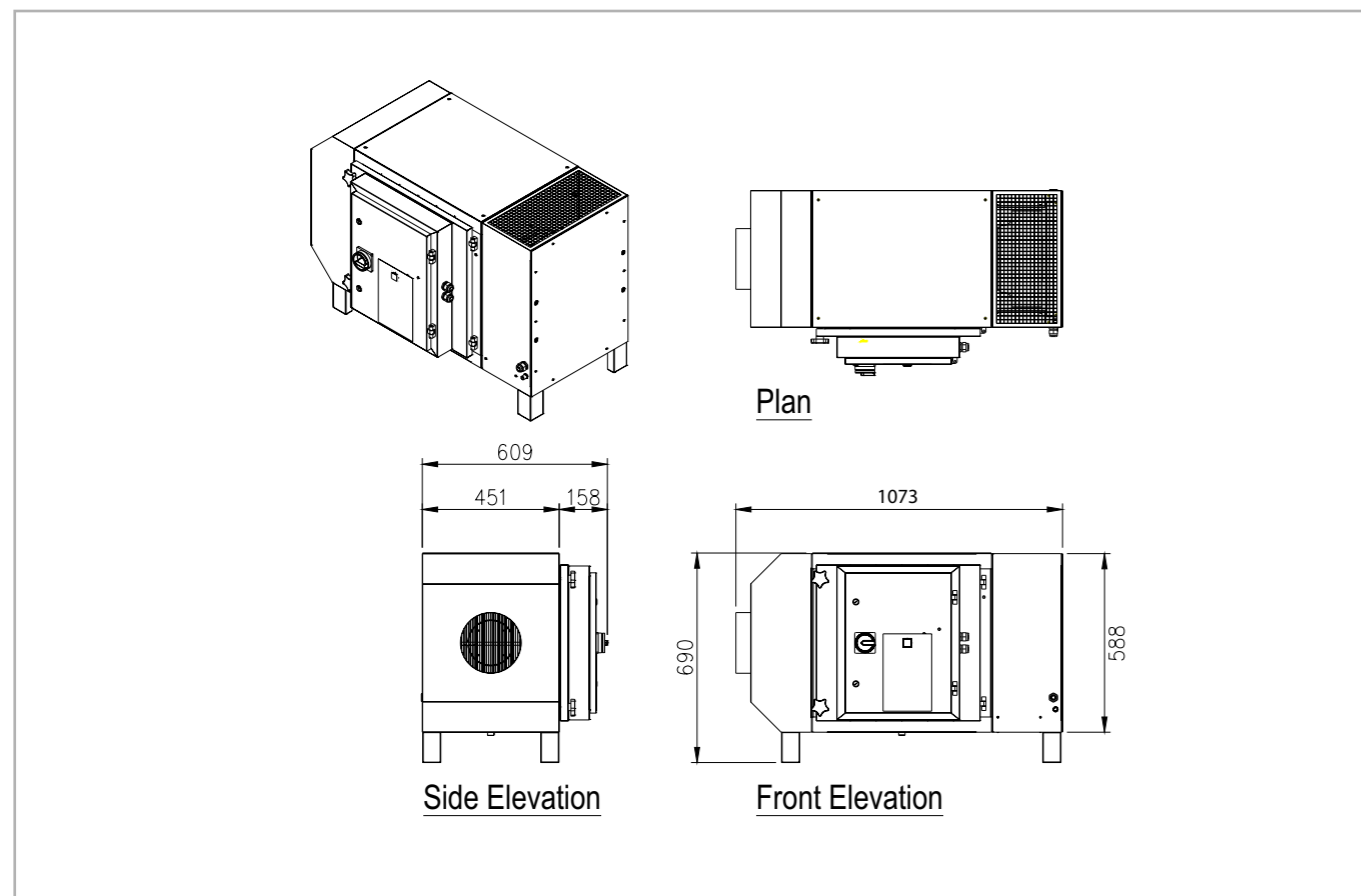

ESP HORIZONTAL 4000

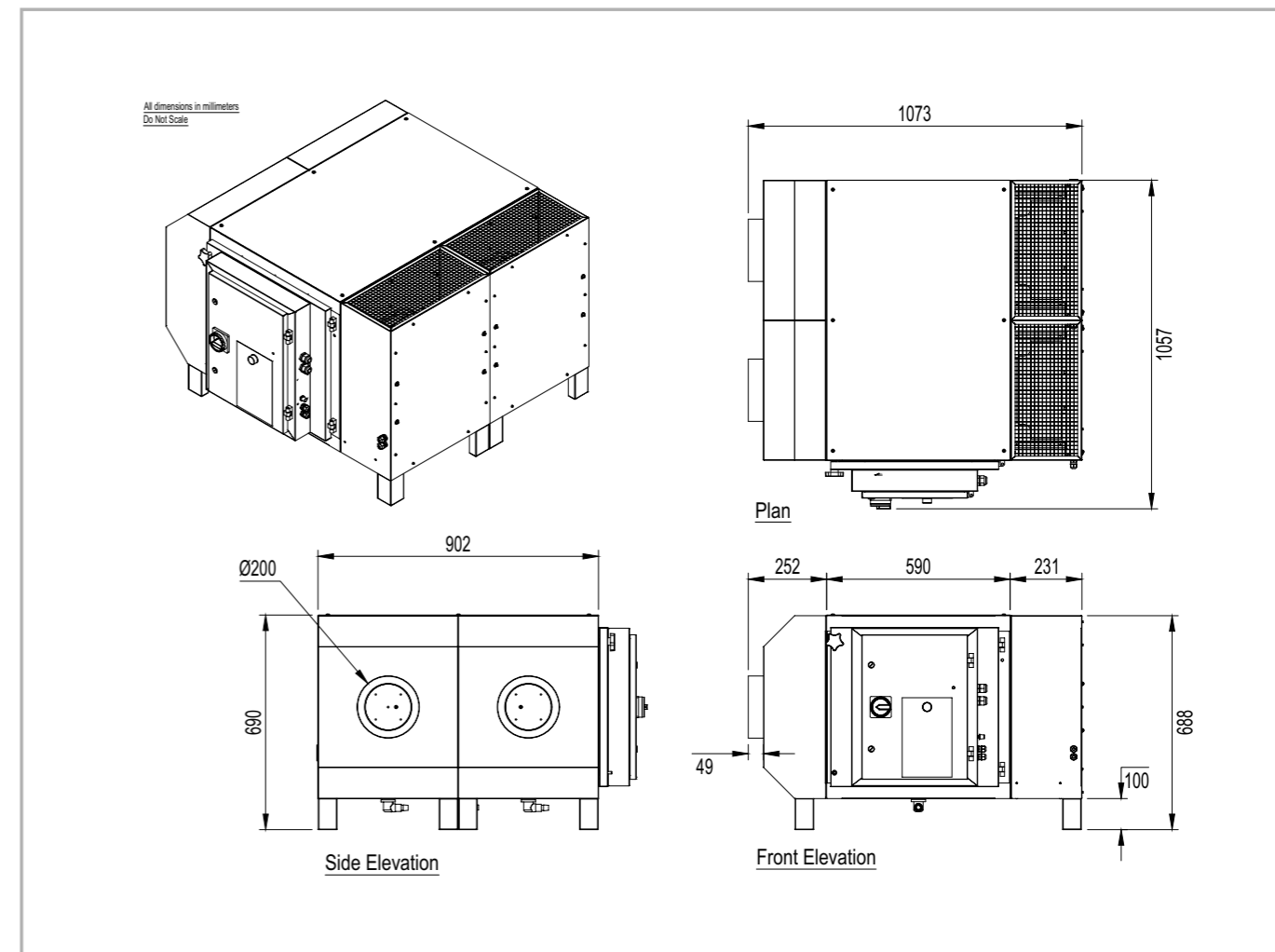

ESP CENTRALISED

1500 | 3000 | 4500 | 6000

Our Electrostatic Precipitators, or ESPs, are ideally suited to larger volumes of smoke, fumes and oil mist. The unit's sizeable modular capacity can be configured from 2500m³/h up to 60,000m³/h. They are IP65-rated and have a built-in sump and drain point.

Access doors and replaceable components enable them to be serviced easily and quickly, reducing workshop downtime. In addition, systems can be configured to remove odour control to offer greater comfort within the workshop or industrial environment by lowering the contaminated air that is exhausted into the atmosphere.

Our products are compact, energy-efficient and affordable for small workshops (cellular) but scalable for large turnkey projects (centralised), delivering a significant ROI.



KEY FEATURES

- ▶ Eliminates up to 98% of oil mist, fumes and smoke particles
- ▶ Suited for large air volumes
- ▶ Filters particles down to sub-micron levels
- ▶ Designed with an integral sump
- ▶ Modular in design
- ▶ Designed for industrial application
- ▶ Energy efficient: uses 20–50W
- ▶ Quick and easy service access reducing workshop downtime
- ▶ IP65 rated for outside location

HOW ITWORKS

Our ESP units fit in-line with the workshop ducting and can be configured modularly to cope with all extract volume requirements.

- 01** Smoke, fumes and oil mist particulates
- 02** Air drawn up through the ducting
- 03** ESP - Particulate Control Unit
- 04** Purified air drawn out to exhaust

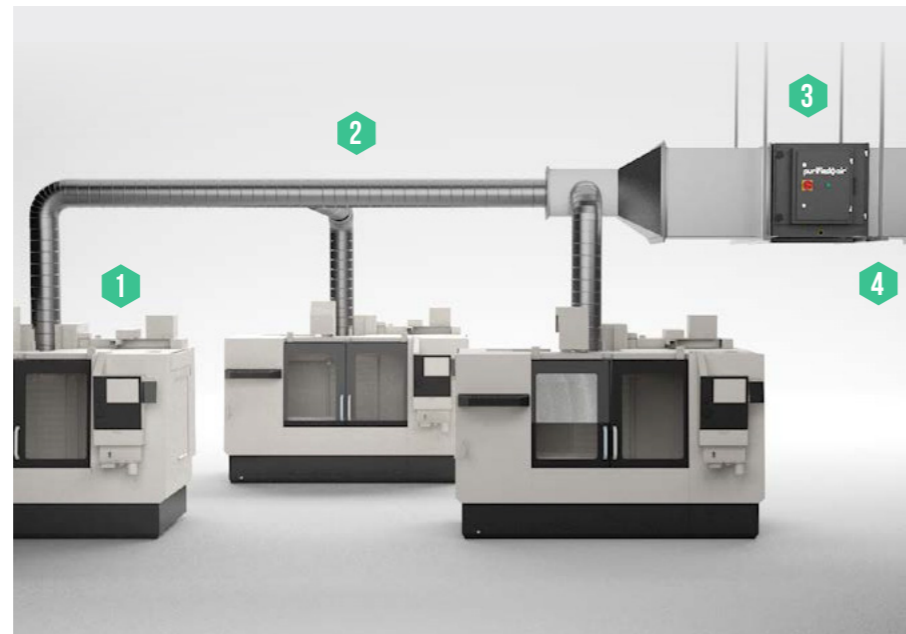

TECHNICAL SPECIFICATION

	ESP 1500	ESP 3000	ESP 4500	ESP 6000
Electrical Supply	220/240V 50Hz	220/240V 50Hz	220/240V 50Hz	220/240V 50Hz
Max Air Volume	Up to 2520 m ³ /h	Up to 5040m ³ /h	Up to 7560m ³ /h	Up to 10080m ³ /h
Max Power Consumption	20w	30w	40w	50w
Dimensions (mm)	W 450 mm	W 900 mm	W 1350 mm	W 1800 mm
	H 630 mm	H 630 mm	H 630 mm	H 630 mm
	D 640 mm	D 640 mm	D 640 mm	D 640 mm
Weight (kg)5	5kg8	5kg	118kg	153kg

THE ELECTROSTATIC PROCESS

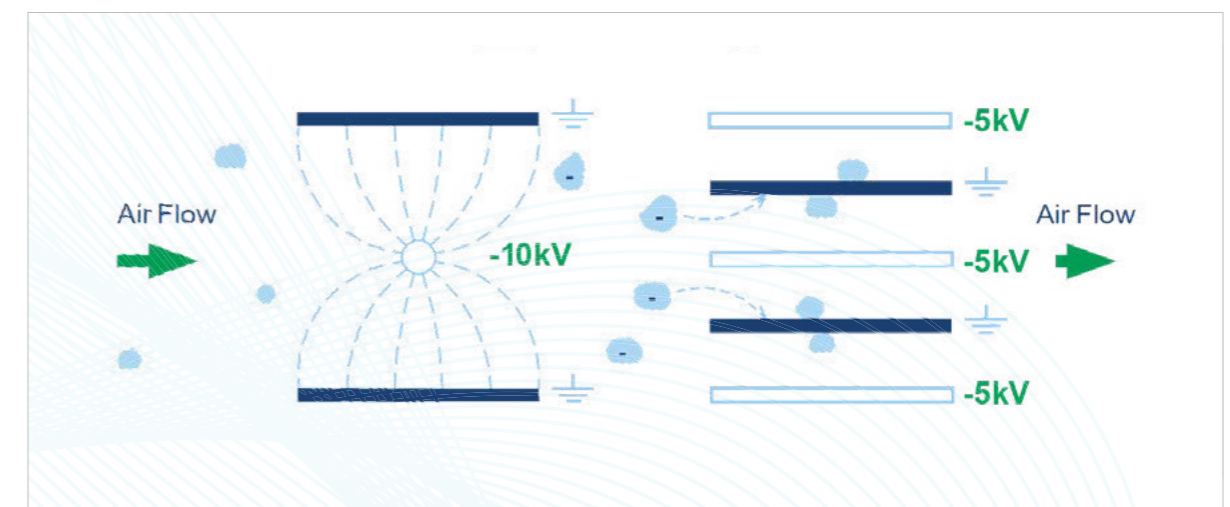

The above diagram shows, in a basic visual, how an electrostatic precipitator works:

As air passes into the combined ioniser / collector cell, the particulates in the air stream are polarised. As they continue through the ioniser and between the collector cell plates,

the polarised particulates are repelled away from the negatively charged plates and attracted to the earthed plates where they stick and so are filtered out of the air flow.

THE BENEFITS OF ELECTROSTATIC TECHNOLOGY

-  Eliminates up to 99% of particles
-  Filters particles down to sub-micron levels
-  Modular design
-  Energy efficient

ABOUT US

Purified Air Ltd. has been striving to find the best and most cost-effective way to filter and control oil, smoke, fat and odour produced by commercial kitchens and residential installation and service since 1984.

Purified Air manufactures filtration and odour control products for stock and bespoke systems, supplying systems to many sectoral brands. The design of each solution is based on the type of food cooked, the cooking process used, and the extracted air volume providing tried and tested purified kitchen exhaust air for Fast Food, Casual Dining and Luxury Concept Restaurant (Fine Dining) markets. By working with these variables, we can design and supply some of the world's best commercial kitchen filtration and odour control systems.

WORLDWIDE COVERAGE

- United Kingdom
- Middle East
- Europe
- Australia

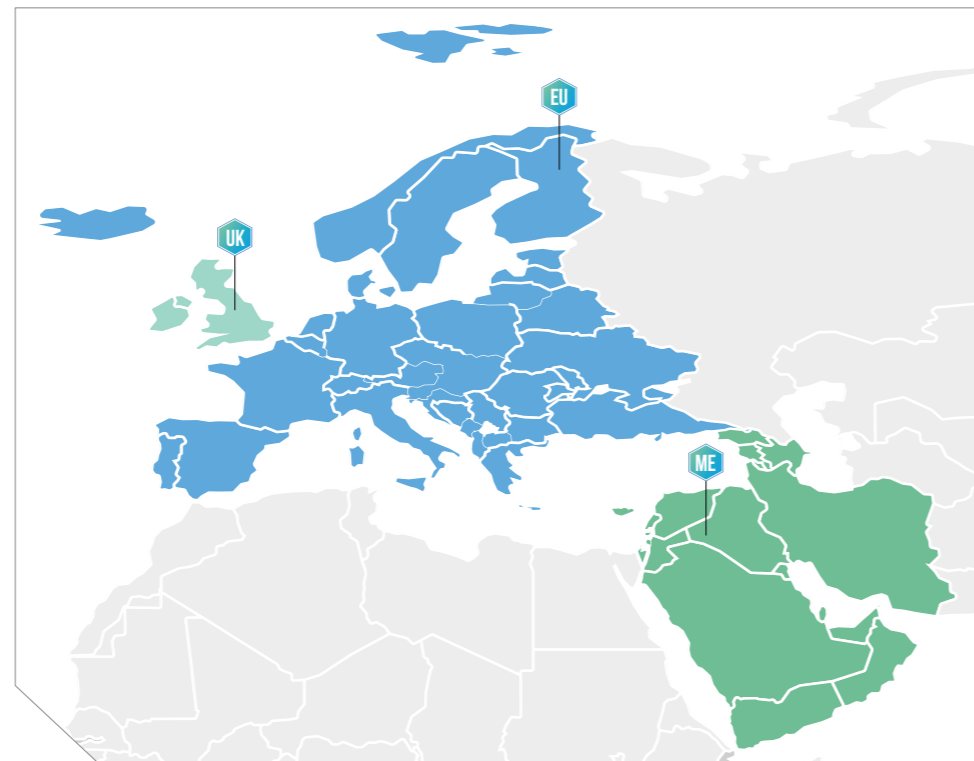

GET IN TOUCH

purifiedair®

AES ENVIRONMENTAL

1300 550 116

sales@aesenvironmental.com.au

9A Pembury Rd, Minto 2566
 NSW, Australia

aesenvironmental.com.au



AES ENVIRONMENTAL

aesenvironmental.com.au

purifiedair[®]

purifiedair.com