



FDC SERIES

FORMALIN DISPENSING CABINET



DESCRIPTION

The FDC multi-dispensing fume hood is a compact, recirculating fume cabinet that has been designed to provide operator safety and ease of use in laboratory applications. Capture of fumes is achieved by inward airflow at a velocity of > 0.5 m/s.

The upper housing contains the mains switch, low-airflow alarm, speed control and carbon filter.



Underbench Formalin Storage

APPLICATION

Suitable for use with:

- Formalin / Formaldehyde
- Ethanol
- Sterile Alcamol
- Viraclen (Disinfectant)
- Cavicide
- Isopropylamine

The FDC multi dispensing fume cabinet comes at a nominal size of 800mm width and a depth of 800mm. Cabinets are fitted with a deep pan sump to capture and control spillage during dispensing process. The roomy built-in storage below the sump enables storage for the containment of chemicals in a safe, and controlled manner. The Formalin Dispensing Cabinet can be fitted with or without doors.

A multi active dispensing system coupled with a simple plugin adapter to fit your bottle makes fluid decontamination a breeze, but most important a safe breeze for users.

The standard activated-carbon filter is suitable for use with a wide range of common laboratory fumes. Special-purpose carbon filters for specific applications are available to order. Special-purpose carbon filters for specific applications are available to order.

FEATURES

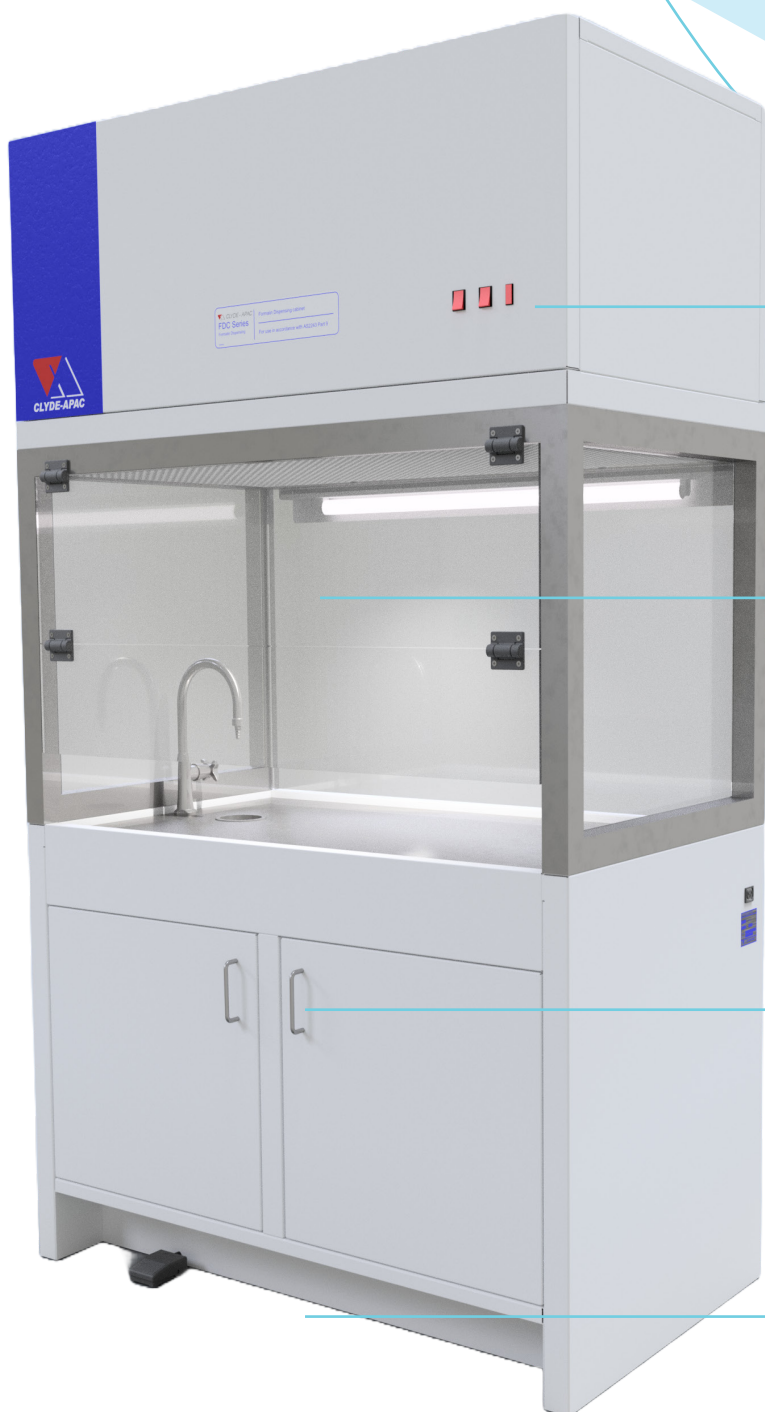

Carbon Filter

The FDC features a carbon filter and fan ventilation to eliminate any objectionable odours or chemical vapors

Stainless steel Sink

Large stainless steel benchtop with tap and sink for dispensing various chemicals.

Storage

Can be supplied with optional doors for extra under-bench storage.

Foot Pedal

For use when dispensing chemicals from the pump into the tap.

ARRANGEMENT

	FDC 120
WIDTH	1280mm
DEPTH	805.40 mm
OVERALL HEIGHT	2200 mm
WORKING HEIGHT	651mm
WORK AREA	1180 x 680 mm

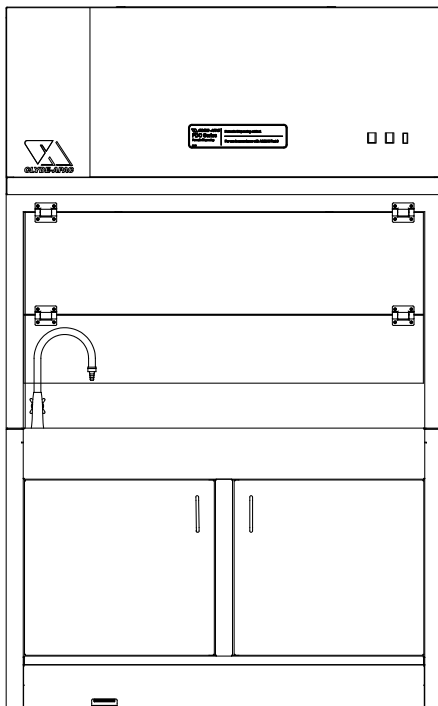
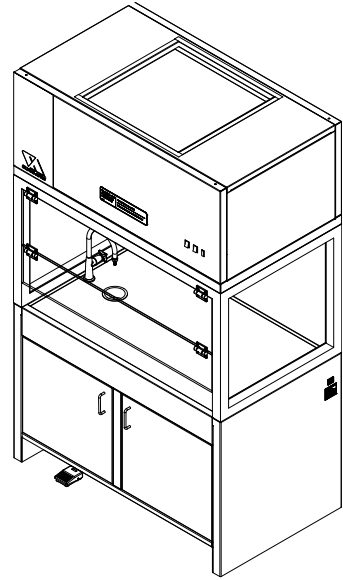

Front view

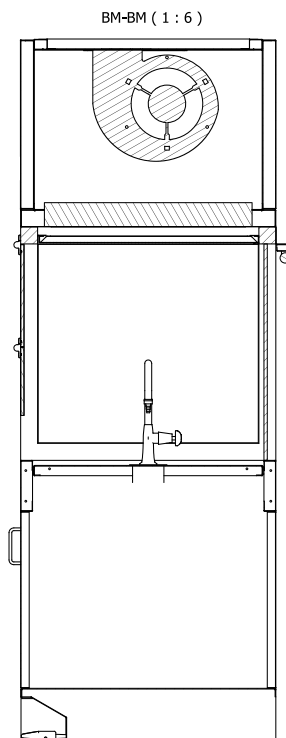

LH Side View

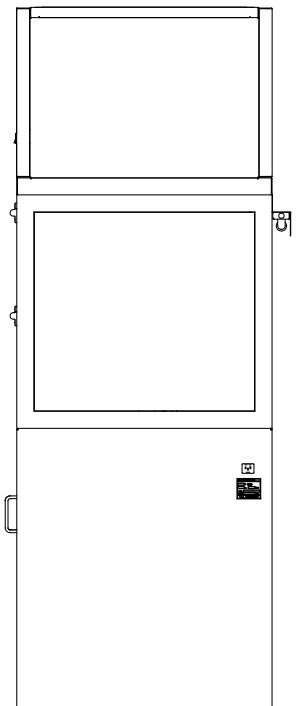

RH Side View

AIRFLOW

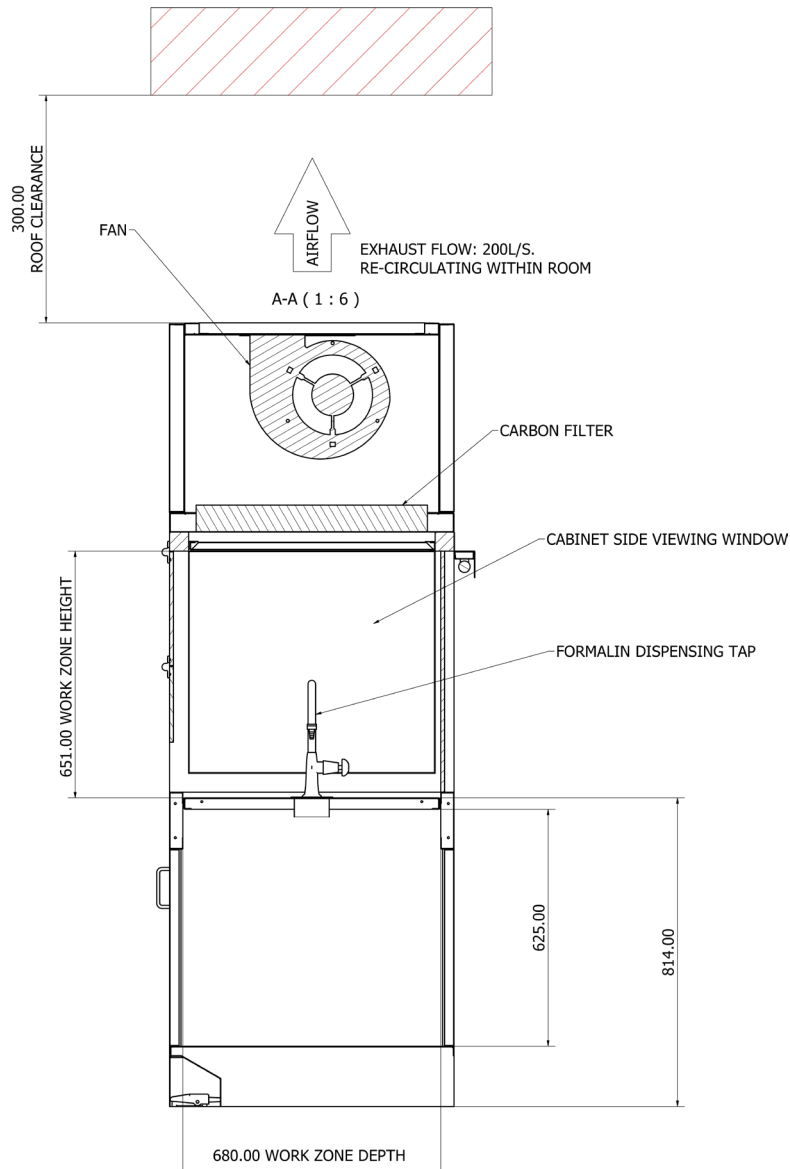

SPECIFICATIONS

FDC Series	
Construction	Baked enamel coated top module.
Colour	Grey
Windows	Clear Perspex
Spillage Tray	Optional polypropylene
Fan	Centrifugal
Electrical Supply	240V, 50Hz
Controls	Mains Power On/Off
Monitoring	Alarm for airflow and filter condition.
Airflow l/s	200
Face Velocity m/s	> 0.5
Carbon filter no.	1 x 4kg
Noise Level dB(A)	58

CERTIFICATION

On-Site Testing

FDC multi dispensing fume hoods are factory tested and certified by a NATA-Accredited laboratory. Additional testing and certification is recommended as follows:

- On site prior to use
- After maintenance or filter replacement
- After re-location
- Anually
- In special circumstances, e.g. if faulty operation is suspected.



AES Environmental maintains an ISO 9001:2015 quality management system to ensure process and product conformance.

Please note: Specifiers and intending users should see AS2243.9, Clause 2.2 which sets out the intended applications and limitations of these cabinets.



AES Environmental is a family owned, engineering and manufacturing business. The company comprises of major brands situated in the Air Filtration, Pollution Control and Life Sciences markets. Those brands and products are market-leading names within their fields ensuring that AES Environmental is capable of fulfilling its goal of providing the market with a single, integrated source for air filtration, clean room and pollution control needs.

Whatever business area you operate in, effective air filtration and pollution control is vital for your products, processes and people. All our products are manufactured in Australia and along with that, we offer installation and service Australia wide, that you can always rely on.

GET TO KNOW US

AES Environmental consists of an Australian head office and manufacturing location in Sydney, NSW, manufacturing and service operations in Perth, WA, Adelaide, S.A. and service operations in Melbourne, Vic. Internationally the business operates manufacturing facilities in Bangkok, Thailand and Newcastle Upon-Tyne, UK.

However large or small the need, with expertise in just about every area of industrial and process filtration and separation, we're ready to help to deliver the products and 'hands-on' support to help you build a better future.

© 2022 AES Environmental | Bulletin No. 15A.08.22 AES441 REV1

In keeping with our policy of continuing product improvement, we reserve the right to alter specifications without notice.

GET IN TOUCH!

AES HEAD OFFICE SYDNEY

-  9A Pebury Rd, Minto, 2566
-  1300 550 116
-  sales@aesenvironmental.com.au
-  aesenvironmental.com.au

